

Job Name: \_\_\_\_\_  
 Purchaser: \_\_\_\_\_  
 Engineer: \_\_\_\_\_  
 Submitted To: \_\_\_\_\_  
 Submitted By: \_\_\_\_\_  
 Unit Designation / Schedule No: \_\_\_\_\_

Location: \_\_\_\_\_  
 P.O No. : \_\_\_\_\_  
 Architect: \_\_\_\_\_  
 Date: \_\_\_\_\_  
 For:  Reference  Approval  Construction  
 Model No: \_\_\_\_\_



**Standard Features:**

- Limited Warranty: 5 years on compressor and 1 year on parts
- Horizontal (front) discharge outdoor unit
- Gold Fin protection on outdoor unit coil
- Compressor short cycle protection
- Wireless remote controller
- On-board diagnostics
- 3 speed fan
- Auto swing louver
- Activated carbon filter
- Large digital display
- Auto restart

**Capacities:**

Cooling (BTU):	9,000
Heating (BTU):	9,000
Cooling Range (BTU):	3,800 - 11,500
Heating Range (BTU):	3,300 - 11,500
Power Supply ( V, Ph, Hz ):	230 - 1 - 60
SEER:	16.0
EER:	11.69
HSPF:	8.50
Refrigerant Type:	R410A
Low Ambient Cooling (Fahrenheit):	64 Degree
Low Ambient Heating (Fahrenheit):	19 Degree

**Indoor Unit Specs:**

Model Number:	GSI091HXB
Maximum / Minimum Fuse Size:	Wired from Outdoor Unit
Control Wire Information:	14 Gauge 4 Conductor Shielded Stranded
Weight (lbs):	18.7
Sound Rating low/med/high( dB ):	48 - 42 - 36
Input Power ( Watts ):	1220
Input Current ( Amps ):	5.41

**Outdoor Units Specs:**

Model Number:	GSU091HXB
Fuse Size ( Amp ):	20
Weight ( lbs ):	88
Sound Rating ( dB ):	55

**Refrigerant Piping Information:**

Maximum Length ( ft ):	50
Maximum Height Difference ( ft ):	16
Liquid Side ( O.D ):	1/4"
Suction Side ( O.D ):	1/2"

**GSI091HXB (INDOOR UNIT):**

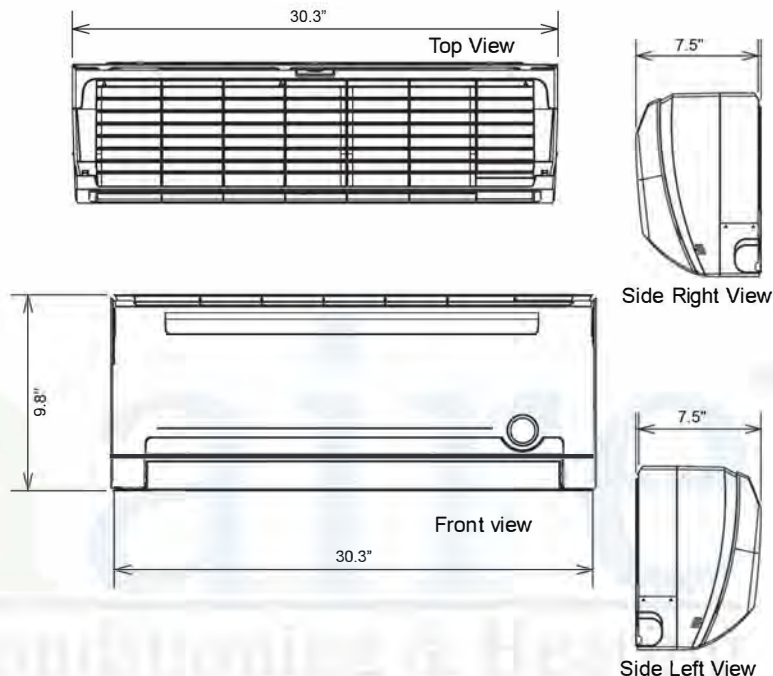

**GSU091HXB (OUTDOOR UNIT):**

