

Job Name: _____
 Purchaser: _____
 Engineer: _____
 Submitted To: _____
 Submitted By: _____
 Unit Designation / Schedule No: _____

Location: _____
 P.O No. : _____
 Architect: _____
 Date: _____
 For: Reference Approval Construction
 Model No: _____

Submittal Data :



Standard Features:

- 5 Year Compressor Warranty
- 1 Year Functional Parts
- Earth Friendly Refrigerant R410A
- 24 Hour On / Off Timer
- Auto-Restart after power loss
- Low Ambient Operations
- LCD Wireless Remote Controller
- Temperature Display on Indoor Unit
- Washable, Reusable Air Filters

Capacities:

Cooling (BTU):	18,000
Heating (BTU):	18,000
Power Supply (V, Ph, Hz):	203 / 208 - 1 - 60
SEER:	13.0
EER:	8.0
HSPF:	13.5
Refrigerant Type:	R410A
Low Ambient Cooling (Fahrenheit):	61 Degree
Low Ambient Heating (Fahrenheit):	14 Degree

Indoor Unit Specs:

Model Number:	GSI180HR
Maximum Fuse Size:	Wired from Outdoor Unit
Minimum Fuse Size:	Wired from Outdoor Unit
Weight (lbs):	40
Sound Rating low/med/high(dB):	44 - 47 - 50
Dehumidification (Pts / hr)	2.99
Input Current (Amps):	6.5

Outdoor Units Specs:

Model Number:	GSI180HR
Maximum Fuse Size (Amp):	30
Minimum Fuse Size (Amp):	20
Weight (lbs):	143
Sound Rating (dB):	60

Refrigerant Piping Information:

Maximum Length (ft):	66
Maximum Height Difference (ft):	33
Liquid Side (O.D):	3/8"
Suction Side (O.D):	5/8"

GSI180HR (INDOOR UNIT):

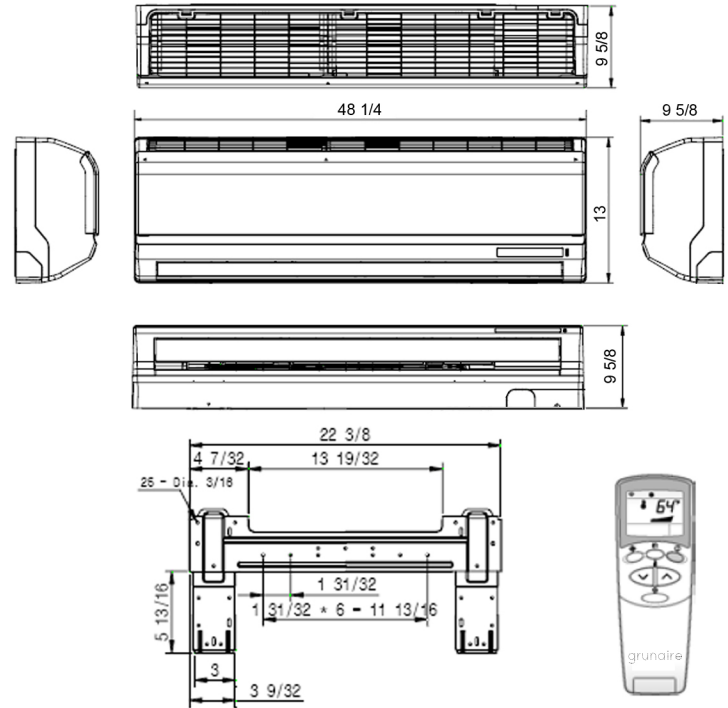

GSI180HR (OUTDOOR UNIT):

